

3M™ D Sub Plug

8200 Series

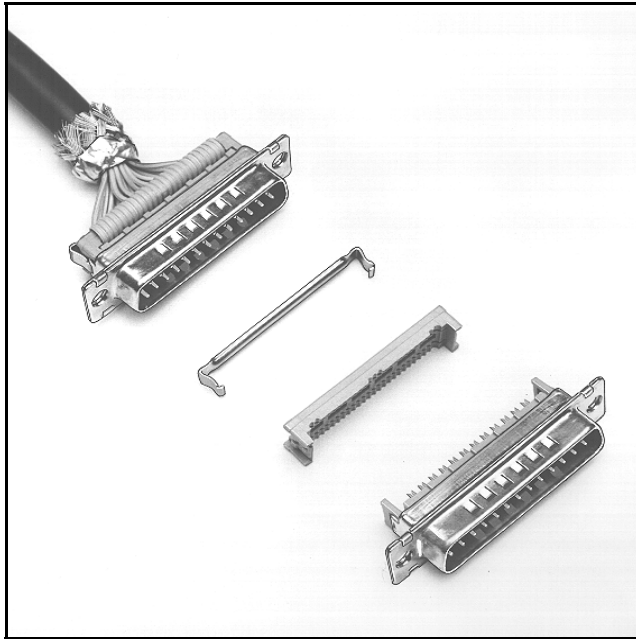

- Available in either open or closed end cover
- Available with dimples to aid in EMI/ESD protection
- Improved metal strain relief hooks directly to metal shell
- Low profile
- Four mounting options
- RoHS* compliant

Date Modified: August 11, 2005

TS-0234-23
Sheet 1 of 3

Physical

Insulation

Material: Glass Filled Polyester (PBT)

Flammability: UL 94V-0

Color: Gray

Contact

Material: Copper Alloy

Plating:

Underplating: 100 μ" [2.54 μm] Nickel - QQ-N-290, Class 2

Wiping Area: 30 μ" [0.76 μm] Gold - MIL-G-45204, Type II, Grade C

Shell Material: Steel

Plating: Tin

Strain Relief Material: Stainless Steel .016 (0.40) Thick

Wire Accommodation: 26 and 28 AWG Solid or Stranded

Marking: 3M Logo and Contact Position Numbers

Electrical

Current Rating: 1 A

Insulation Resistance: $> 1 \times 10^9 \Omega$ at 500 VDC

Withstanding Voltage: 1000 Vrms at Sea Level

Environmental

Temperature Rating: -55°C to +105°C

*RoHS = Directive 2002/95/EC, Restriction of the Use of Certain Hazardous Substances in Electrical and Electronic Equipment
"RoHS compliant" means that the product or part does not contain any of the following substances in excess of the following maximum concentration values in any homogeneous material, unless the substance is in an application that is exempt under RoHS: (a) 0.1% (by weight) for lead, mercury, hexavalent chromium, polybrominated biphenyls or polybrominated diphenyl ethers; or (b) 0.01% (by weight) for cadmium. Unless otherwise stated by 3M in writing, this information represents 3M's knowledge and belief based upon information provided by third party suppliers to 3M.

UL File No.: E68080

3M™ D Sub Plug

8200 Series

Contact Quantity	Dimensions					
	A	B	C	D	E	F ± .008
09	1.23 [31.2]	.67 [17.0]	.98 [24.9]	.46 [11.7]	.67 [17.0]	.70 [17.7]
15	1.56 [39.6]	1.00 [25.4]	1.31 [33.3]	.76 [19.3]	.99 [25.2]	1.03 [26.2]
25	2.10 [53.3]	1.54 [39.1]	1.85 [47.0]	1.27 [32.3]	1.54 [39.1]	1.57 [39.9]
37	2.74 [69.6]	2.18 [55.4]	2.50 [63.5]	1.87 [47.5]	2.19 [55.6]	2.22 [56.4]

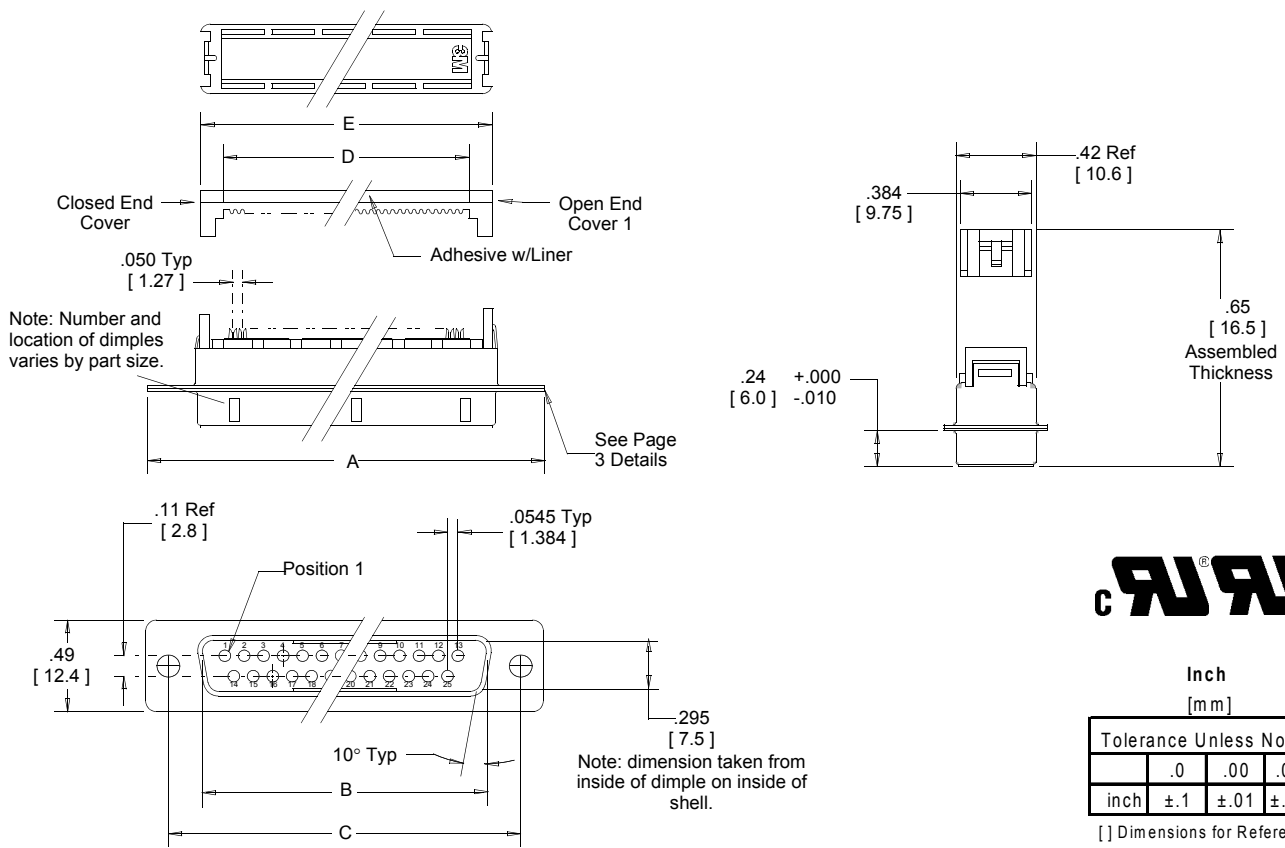

Inch [mm]

Tolerance Unless Noted			
	.0	.00	.000
inch	±.1	±.01	±.005

[] Dimensions for Reference Only

Ordering Information

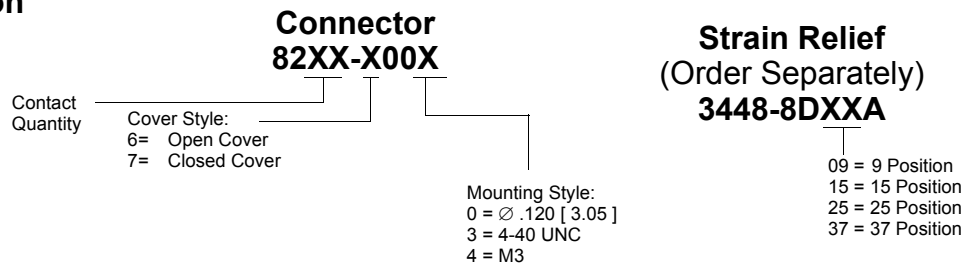

Application tools: 3640 press (or equivalent), 3443-106N locator plate, 3442-39N platen (9 & 15 pos) or 3442-41N platen (25 & 37 pos).

TS-0234-23
Sheet 2 of 3

3M™ D Sub Plug

8200 Series

Mounting Method*	Contact Quantity	Dimensions						
		A1	B1	C1	D1	E1	F1	G1
Front	9	.87 [22.0]	.44 [11.2]	.98 [24.9]	.49 [12.5]	.51 [13.0]	.26 [6.6]	.12 [3.1]
	15	1.20 [30.5]	.60 [15.2]	1.31 [33.3]	.66 [16.8]			
	25	1.74 [44.2]	.87 [22.1]	1.85 [47.0]	.93 [23.6]			
	37	2.39 [60.7]	1.20 [30.5]	2.50 [63.5]	1.25 [31.8]			
Rear	9	0.81 [20.6]	.40 [10.2]	.98 [25.0]	.49 [12.5]	0.45 [11.4]	0.22 [5.8]	.12 [3.1]
	15	1.13 [28.7]	.57 [14.5]	1.31 [33.3]	.66 [16.8]			
	25	1.67 [42.4]	.84 [21.3]	1.85 [47.0]	.93 [23.6]			
	37	2.33 [59.2]	1.16 [29.5]	2.50 [63.5]	1.25 [31.8]			

Front Mount-The connector is mounted in front of the panel.
Rear Mount-The connector is mounted behind the panel.

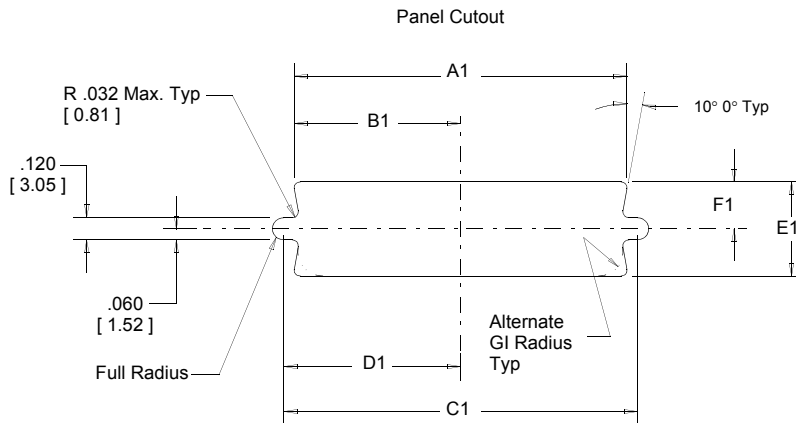

Mounting Styles

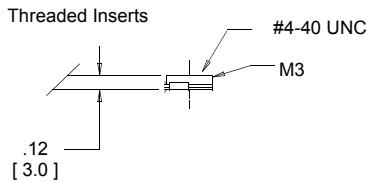
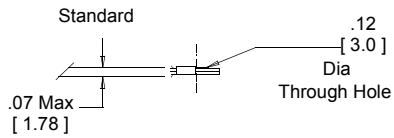

Strain Relief

(Order Separately or with Connector)

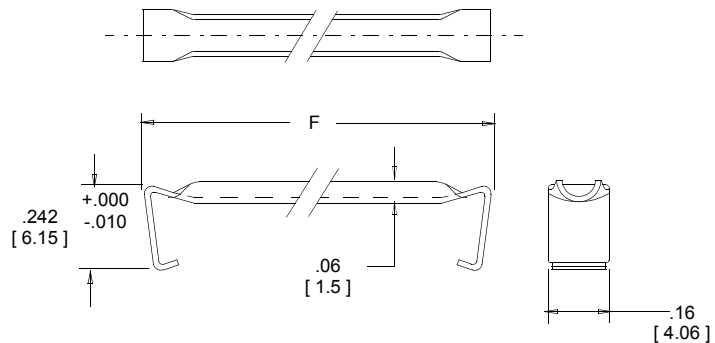

TS-0234-23
Sheet 3 of 3